

**USER INSTRUCTION**  
READ CAREFULLY AND KEEP WITH THE CASE

**用户手册**

使用前请仔细阅读本说明书，并妥善保存以备日后查阅



**DAWN**



Model/ 型号

**DAWN**

Manufacturer/ 制造商

EPTA (Qingdao) - The Shibei Park of Qingdao High & New Develp. Zone,  
(Hongdao), Qingdao, China

Tel: 0532-87838650 Fax: 0532-87837908

爱普塔(青岛)商业设施有限公司 - 青岛市北高新区(红岛北)

**ENGLISH** ————— 8

中 文 ————— 13

## **INTRODUCTION — 简介**

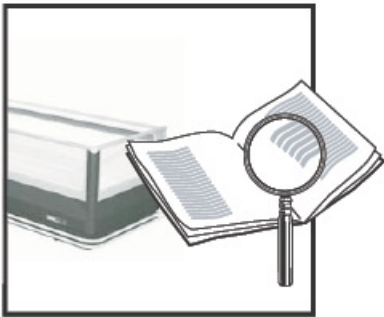

The present booklet has been formulated in a simple and rational way, in order for the reader to get deeply acquainted with his DAWN showcase. Please, read it carefully and keep it with the machine. The manufacturer assumes no responsibility for any personal injury or property damage which may be caused by non-compliance with the instructions contained in this booklet. Whoever operates the machine must have read this manual beforehand.

本说明书简明扼要的对产品进行阐述,用户可以深入了解产品。请在陈列柜使用前仔细阅读本说明书并妥善保管。厂商对未按照本说明书的操作而引起的人身伤害或者财产损失不承担任何责任。每个使用陈列柜的用户务必在使用前仔细阅读本说明书。

DAWN

fig. 1

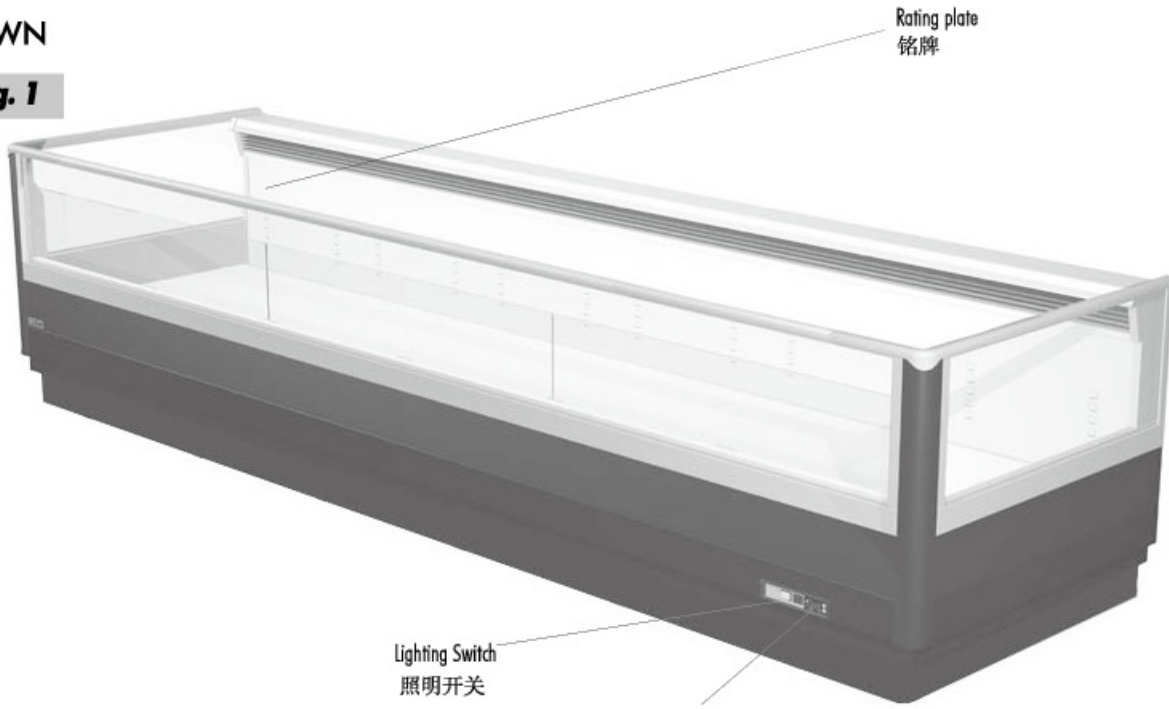

fig. 2



fig. 3

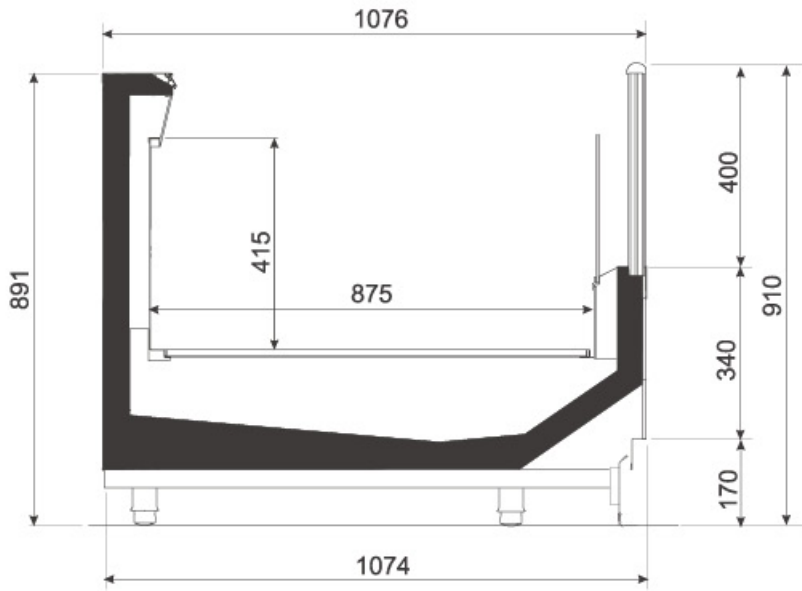

fig. 4



**fig. 5**

### DAWN HG400



**fig. 6**

### DAWN BACK TO BACK

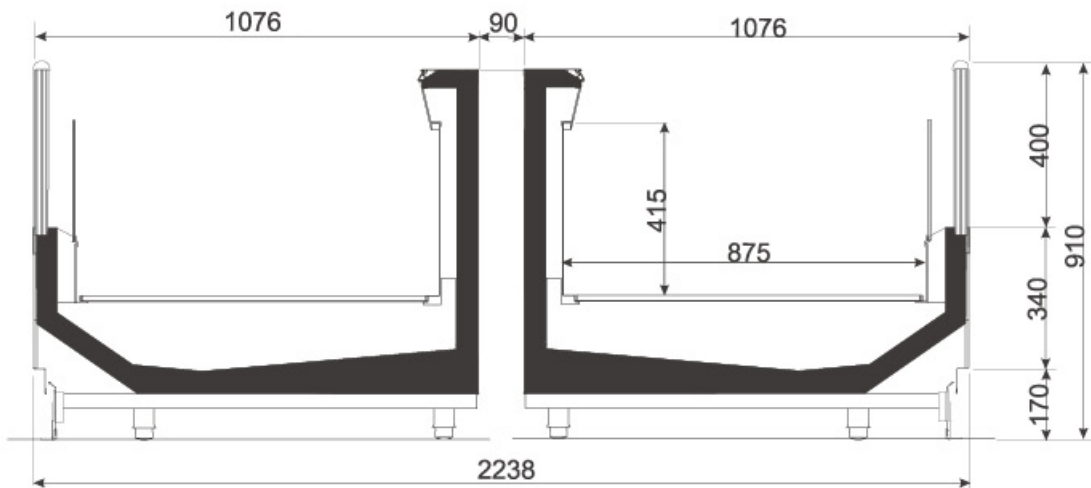

lengths/长度: 1880 - 2500 - 3750 mm + head case/端头柜



fig. 7

tab. I

Weight of the case 陈列柜重量		Normal weight 正常重量 (kg)	Packed weight 含包装重量 (kg)	Lateral end 侧板
		F. 3000	F. 3000	
DAWN	1880	215	260	40/60
	2500	290	350	
	3750	490	540	
Head case / 端头柜		270	320	-

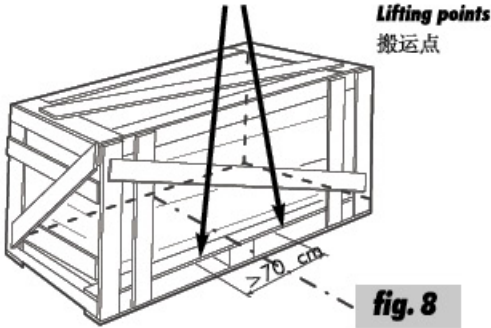

fig. 8

CONSIDER AN INCREASE OF 150mm IN WIDTH, LENGTH AND HEIGHT TO ALLOW FOR PACKING DIMENSIONS.  
包装尺寸在陈列柜宽度、长度和高度上各加150毫米。

ambient conditions / 使用环境

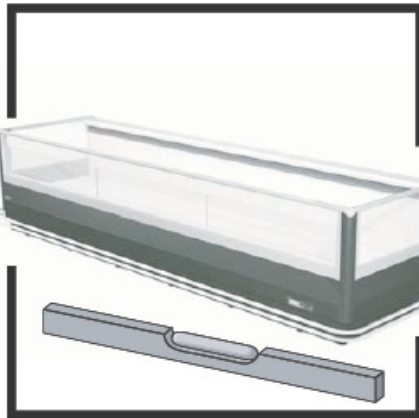

fig. 9

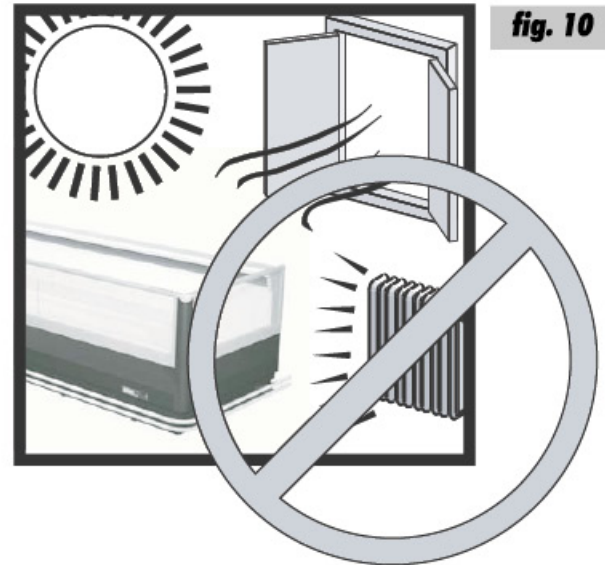

fig. 10

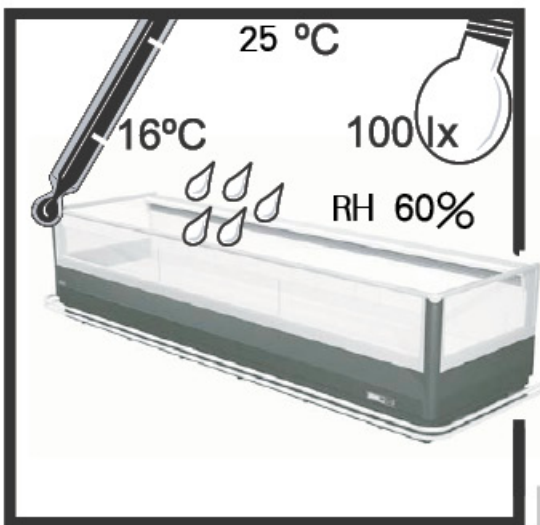

fig. 11

tab. II

Type of room / 房间类型	CLOSED / 封闭
Temperature / 温度	25 °C
Relative humidity / 相对湿度	60% RH
Lighting / 照明	100 lx

tab. III

		DAWN			
		1880	2500	3750	MT
PowerVoltage / 电压		380-400 V 3Ph+N/ 50 HZ			
Rated output / 额定输出 (W)	BT	155	180	265	210
	TN	115	130	195	165
	BT Hot gas	155	180	265	210
	Spalle/Ends	54	54	54	54
	RAB	39	53	79	-
Defrosting power / 解霜功率 (W)	BT	2125	2830	4425	2460
	TN	655	860	1355	295
	BT Hot gas	685	890	1355	830
	Spalle/Ends	54	54	54	54
	RAB	39	53	79	-
Degree of protection against humidity 防潮等级		Ip 21			
Climatic class / 气候类型		H3 ( 25 °C / 60 % )			

RAB: Trim heater on counter/化霜电热丝

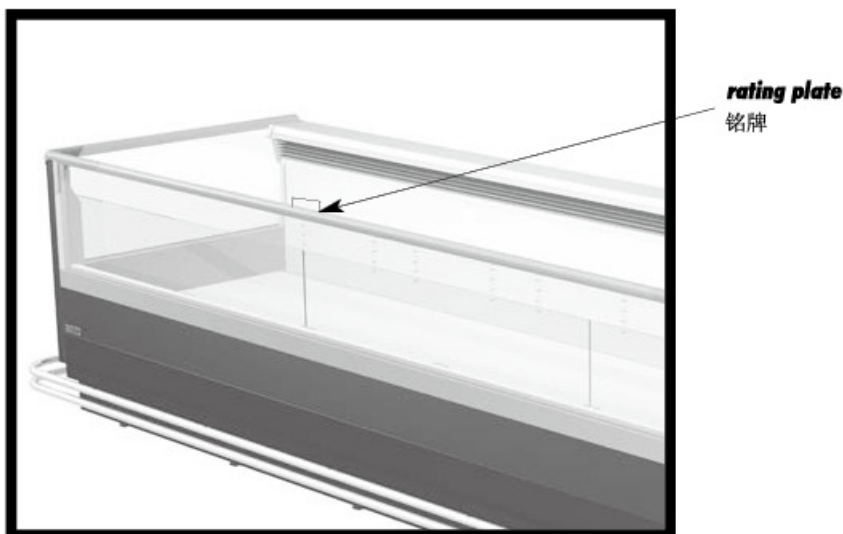

fig. 12

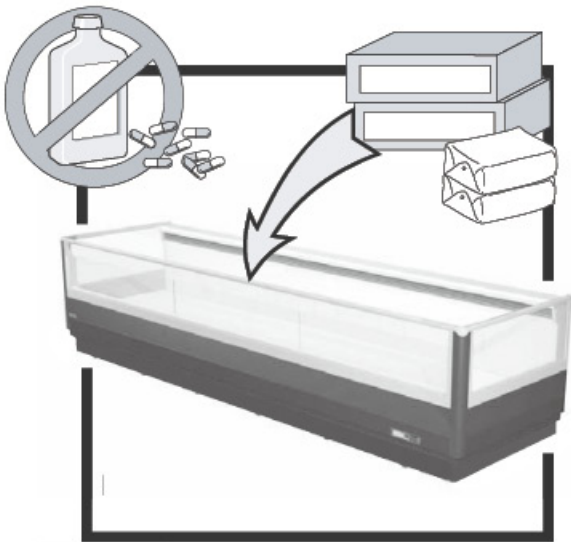

fig. 13

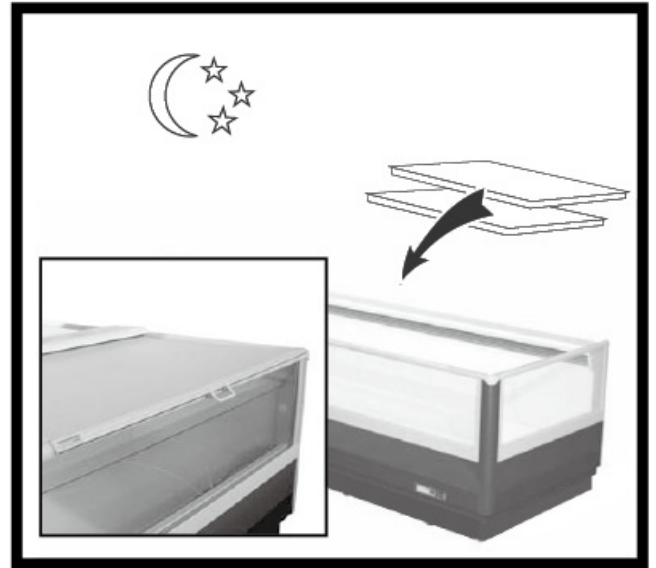

fig. 14

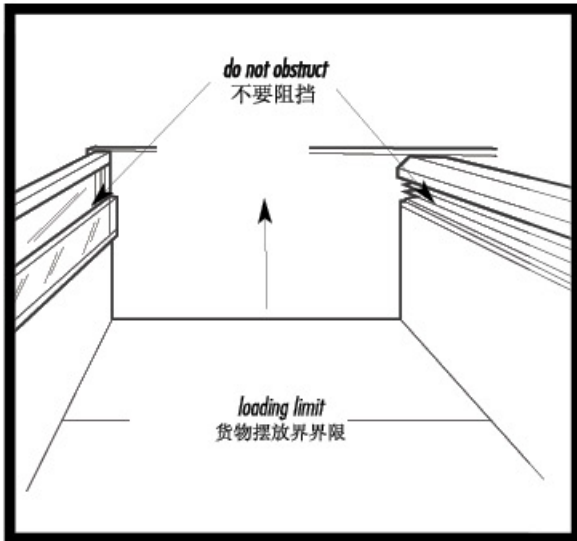

fig. 15

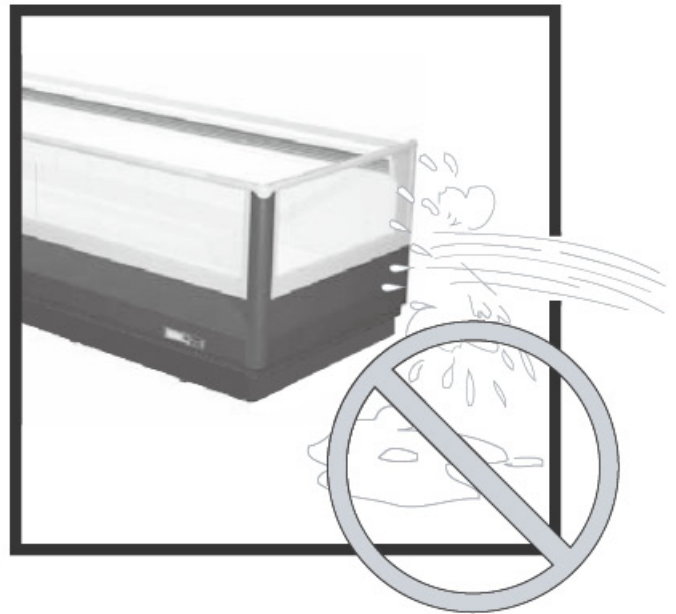

fig. 16

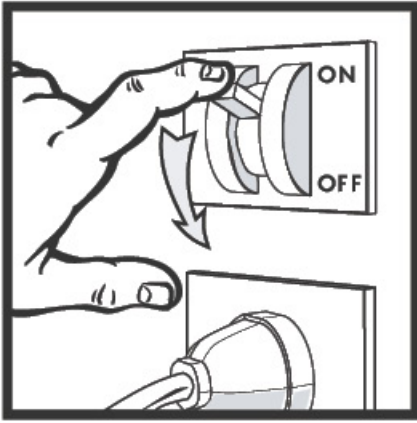

fig. 17



fig. 18

fig. 19



1

2



Main electrical switch board  
主控制面板



## **1. DESCRIPTION**

The low-temperature version of the DAWN showcase is meant for the preservation of ice-creams and frozen food (class L), whereas its positive-temperature version is for the preservation of fresh pre-packed food (class M). DAWN display cases are available in two different widths and lengths, in various aesthetic styles and with different possibilities, as set forth in the main features section, which clearly illustrates dimensions too in drawings 1, 2, 3, 4, 5, 6, on pages 2 and 3. As for weights, packing included and excluded and packing sizes, see table I on page 4. A wide variety of optional accessories is also available for enhanced functions. To this respect, contact the authorised after-sales service only.

## **2. TRANSPORTATION**

The cabinet is contained in a crated package that enables transportation by the use of fork lift trucks. Handle the machine on its own pallet or on a similar platform; use a fork lift truck, either manual or electric, provided it is adequate for handling such appliances and it has the requisite lifting capacity (see page 4 - figs. 7 / 8 and table I). Handling is reserved for the authorised after-sales service.

## **3. DELIVERY AND STORAGE**

Prior to accepting the case from the carrier, check the conditions of the package. If it is showing visible damage, the machine too may have suffered some consequences. If so, unpack the machine in the presence of the carrier and sign, under qualification, the delivery bill. The manufacturer disclaims all liability for damage caused by transportation or incorrect handling during storage. Unpacking is reserved for the authorised after-sales service. Storing temperature must be between -25°C and +55°C, air humidity between 30% and 95%. Keep the case away from direct sunlight and from the elements.

## **4. INSTALLATION AND AMBIENT CONDITIONS**

The cabinet must not be installed in premises containing explosive gas substances. It can neither be used in the open nor exposed to rain.

Prior to connecting the cabinet, make sure that the rating plate data correspond to the characteristics of the existing electrical system (see page 5 - fig. 12 tab. III). For correct operation, the machine must be placed on a level floor (see page 4 - fig 9), far from sources of heat and/or direct sunlight, doors, windows, fans or ventilation outlets (see page 4 - fig.10). It must be granted a reasonable free front area for customer service.

The room where the appliance is installed must comply with the requirements set forth on page 4, fig. 11 and tab. II.

The installation of the display case is restricted to Manufacturer's technical after-sales service, who are in possess of the relevant installation manuals.

## **5. ELECTRICAL CONNECTION**

The refrigerator must be installed by professionally qualified personne and in accordance with the instructions provided by the manufacturer and with local regulations. Incorrect installation may cause harm to persons, animals and

property. The manufacturer assumes no responsibility for such damages.

Make sure that power supply voltage corresponds to the values appearing on the rating plate of the refrigerator. Consider also that the maximum allowable power voltage variation is  $\pm 6\%$ .

**IMPORTANT: THE REFRIGERATOR MUST BE PROPERLY EARTHED.** The manufacturer disclaims all responsibility for damage resulting from non-observance of this safety principle. If the refrigerator must be installed far from the power point, make certain that the connection complies with the standards in force.

**THE MANUFACTURER DISCLAIMS ALL RESPONSIBILITY FOR ANY PERSONAL INJURY OR PROPERTY DAMAGE ARISING FROM INCORRECT INSTALLATION.**

## **6. TECHNICAL SPECIFICATIONS**

The built-in electrical installation is composed of control and safety devices lodged in the base of the appliance. The wiring diagrams and settings lists are contained in a sealed plastic envelope together with the present booklet. Keep such documents with this booklet. The technical data, which are also reported on the rating plate inside the display case (see fig. 12 on page 5) are shown on table III, page 5. The sound level generated by the running refrigerator is below 70 dB(A). The refrigerator generates no harmful vibrations.

WE HEREBY DECLARE THAT THE SHOWCASE AT ISSUE COMPLIES WITH D.L. (DECREE LAW) DATED 25/JAN/1992 N° 108 AS EXECUTING ECC DIRECTIVE 89/109 ON MATERIALS AND OBJECTS FIT FOR CONTACT WITH EDIBLES.

WE HEREBY DECLARE THAT THE SHOWCASE AT ISSUE IS ADEQUATE FOR THE PRESERVATION OF FROZEN PRODUCTS IN COMPLIANCE WITH LAW N° 283 DATED 30/APRIL/42 AND SUBSEQUENT AMENDMENTS, AND DECREE LAW OF 29/JAN/81 PUBLISHED IN THE OFFICIAL GAZETTE dated 26/MARCH/81 N° 85.

Thermostat adjustment is restricted to the technical after-sales service only.

## **7. LOADING PRODUCTS**

Switch the cabinet on through the wall cutoff switch. As soon as the cabinet is on it will start its cooling cycle. Allow about two hours before loading any products, which must already be at their preservation temperature. THE CABINET IS FACTORY-REGULATED FOR THE ANTICIPATED PERFORMANCE.

When loading products make certain that:

- they are similar in size and type;
- the load limit line is not exceeded and products do not hamper correct cool air circulation (see fig. 15, page 6).

## **8. USE**

The showcase was designed and manufactured exclusively for the display of ice-creams and frozen food in its low-temperature version (class L), of pre-packed fresh food in its positive temperature version (class M). Its function is preserving food temperature, not lowering it. Therefore, when introduced, THE FOODSTUFFS MUST BE AT THEIR CONSERVATION TEMPERATURE. Do not load foods that have undergone heating. Use padded gloves when handling ice-creams and frozen food.

For best cabinet operation we recommend:

- loading the products as explained in the preceding section;
- using night covers or night curtains, if any are installed, during closing hours (fig. 14): this avoids unnecessary energy consumption and helps better product preservation;

#### DESCRIPTION OF CONTROLS

The Leopard display cases have a control panel in the base. This control panel lodges a remote thermometer/remote thermostat for temperature display and control through appropriate keys.

Temperature regulation is restricted to the after-sales personnel.

Do not remove the panel protecting of the electric control board for no reason whatsoever.

#### DEFROSTING

The number and duration of defrosts of the cases are factory-set.

The user must never alter defrost adjustment.

The cases are supplied as including a U-trap for their connection to the sewer system (WHICH MUST BE CARRIED OUT BY THE AFTER-SALES SERVICE IN CHARGE OF INSTALLATION).

### **9. PRESCRIPTIONS AND RESTRICTIONS**

KEEPING PHARMACEUTICAL PRODUCTS, GLASS BOTTLES OR FLASKS IN THE DISPLAY CASE IS STRICTLY FORBIDDEN as they could get broken and entail a safety hazard (fig. 13).

Do not remove covers or panels when it requires the use of tools. DO NOT REMOVE THE ELECTRIC CONTROL BOARD COVER.

Do not expose the display case to atmospheric agents (fig. 17).

Do not spill water directly or indirectly on the display case (fig. 16). Do not touch the machine with damp or wet hands or feet; do not use it while barefoot (fig. 18).

Do not step on the bumper rail.

ANY OTHER USE NOT EXPLICITLY MENTIONED IN THIS BOOKLET MUST BE CONSIDERED AS HAZARDOUS. THE MANUFACTURER DISCLAIMS ALL LIABILITY FOR ANY DAMAGE RESULTING FROM IMPROPER, INCORRECT OR UNREASONABLE USE.

### **10. ORDINARY MAINTENANCE**

ATTENTION! BEFORE MAINTENANCE OR CLEANING, DISCONNECT THE REFRIGERATOR FROM THE POWER SUPPLY USING THE WALL MAIN CUTOFF SWITCH (fig. 19).

IMPORTANT: During maintenance or cleaning operations, be sure that the light in the working area is sufficient. If necessary, use an additional source of light. Mind also the hot and moving parts marked with the relevant symbol. The use of heavy-duty gloves is recommended.

## CLEANING THE CABINET

1) Every week clean the outer surfaces of the display case with mild soap or detergent in lukewarm water only. Wipe carefully with a soft cloth. Never clean it using inflammable or scouring agents alcohol, acetone or solvents. NEVER CLEAN THE DISPLAY CASE BY THE USE OF WATER JETS (fig. 16). Clean glass surfaces using glass-cleaning products only. The use of water is not recommended here, as it may cause scale to build up.

2) Every month clean the cabinet's inside surfaces following the instructions provided in the preceding item and those indicated herebelow:

- Disconnect the cabinet from the power mains by the wall main cutoff switch (fig. 19).
- Empty the appliance, store its content in coldrooms or refrigerators that are adequate for keeping the requisite preservation temperature.
- Wait until the display case has reached ambient temperature.
- Clean the appliance inside using mild soap in lukewarm water and then wipe carefully with a soft cloth.
- After having carefully checked that the cabinet is completely dry, reassemble it and switch it on.
- Allow a couple of hours before loading the products back again.ser.

3) Defrost the display case every three months to let the ice that may have formed between the evaporator fins melt, since frost may otherwise prevent correct operation. Proceed according to the instructions for cleaning the inside surfaces, item 2, but allow a longer wait time for the ice to melt completely.

Any maintenance operation not dealt with above, must be carried out by the authorised after-sales service or by qualified personnel.

## **11. EMERGENCY SITUATIONS**

1) The cabinet will not start or will not keep on working:

- There may be a general black-out;
- The wall main switch may be off.

If power failure is not due to the above causes, call the nearest after-sales service immediately, empty the display case and store the foods in coldrooms or refrigerators that may ensure preservation temperature.

2) The display case will not cool properly:

- The condenser may be dirty and therefore unable to exchange heat. If it is obstructed by dust or dirt, clean thoroughly as explained in section 10.
- Make sure that the product load is correct.
- If the display case has not been defrosted for longer than 3 months, defrost and clean it before starting normal operation (see section 10, item 3).
- Make sure that the case is not exposed to sources of heat or draught.
- Check that the display case is perfectly horizontal by the use of a spirit level and that ambient conditions comply with the requirements of page 3.

Should insufficient cooling persist, resort to the nearest after-sales service.

IN CASE OF A GAS LEAK OR FIRE, do not breathe inside the room that houses the cabinet before having aired it properly. Turn the cabinet off by the main switch ahead (see fig. 19). DO NOT USE WATER BUT ONLY DRY EXTINGUISHERS TO PUT OUT THE FIRE.

3) The cabinet operates noisily:

- Make sure that screws and bolts are closed tight.
- Check that the display case is perfectly horizontal by the use of a spirit level.

Should the inconvenience persist, resort to the nearest after-sales service.

## **12. AFTER-SALES SERVICE**

Should it be necessary to resort to technical assistance, contact your sales person immediately. If spare parts are needed, always refer to your after-sales service: insist on the use of original spare parts.

## **13. DISMANTLING AND DISPOSAL**

Please, for the sake of the environment, sort the parts and materials composing the cabinet in accordance with the waste disposal provisions in force in your country, so that they can be properly disposed of or recycled. All its parts cannot be treated as solid urban waste, except for the metal parts, which nevertheless are not considered as special waste by most European countries. THE PARTS COMPOSING THE REFRIGERATING CIRCUIT MUST NOT BE SEVERED OR SEPARATED BUT DELIVERED INTACT TO A CENTRE SPECIALISED IN RECYCLING REFRIGERANT GAS.

## 1. 概述

DAWN 低温冷冻陈列柜用来存放冰激凌和冷冻食品（类别L），而 DAWN 常温冷藏柜用于预包装食品的保鲜（类别M）。DAWN 陈列柜分别有两种不同的宽度和长度，多种外观和选择，正如在主要参数章节里提到的，在第2和3页的图1、2、3、4、5、6、里列出了这些型号。对于陈列柜的重量，包含了包装的重量但是未考虑包装尺寸，请参看第4页表I。备有大量的可选件用于扩充陈列柜的功能。此项事宜请与指定的售后服务商联系。

## 2. 运输

这些陈列柜都包装在特殊的木箱里以便于叉车运输。将设备搬运到自带的托盘或类似平台上，使用有足够举重能力能搬运这样陈列柜（参看第4页-图 7/8 和表I）的手动或电动的升降式叉车。由指定的售后服务商实施搬运。

## 3. 交货和存放

在签收货物前，请先检查陈列柜的外包装。外包装的损坏有可能引起陈列柜的破损。如果外包装确有损坏，请在货运商面前拆箱并在交货单上签字，请保管好交货单并保留对承运商索赔的权利。厂商对因运输或在存放中的不正确搬运而引起的损坏不承担任何责任。拆箱工作由指定的售后服务上进行。陈列柜的存放温度介于-25℃和55℃之间，空气湿度在30%和95%间。陈列柜要远离阳光直射和电子元件。

## 4. 安装和使用环境

注意：陈列柜绝对不能安装在含有爆炸性气体的房屋里，也不能在露天或雨中使用。

在连接陈列柜前，请确认陈列柜铭牌中的数据 and 现有的参数相符（参看第5页-图12和表III）。正确的操作：将陈列柜放在水平地面上（参看第4页-图9），远离热源和（或）阳光直射、门、窗、风扇或通风口（参看第4页-图10）。在陈列柜前方要留出适当的空间便于顾客取货。

安装陈列柜的房间里必须符合第4页-图 8 和表II中列出的要求。

注意：陈列柜的安装只能由厂家指定的售后服务技术人员进行，他们有相关的安装手册。

## 5. 电气连接

陈列柜的安装必须由专业人员按照厂商提供的使用说明书和当地的规定进行。厂商对因不正确的安装造成的对人、动物的伤害及财产损失不承担任何责任。

确认电源电压符合陈列柜铭牌中标明的电压数值。请注意最大的电压变化范围为 $\pm 6\%$ 。

重要事项：陈列柜必须正确接地。厂商对因不遵守这一安全准则而造成的一切危险后果不承担任何责任。如果陈列柜必安装在远离电源地方，须确保电路按照国家规定正确连接。

厂商对因不正确的电气安装而引起的任何人身伤害或财产损失都不承担任何责任。

## 6. 技术规格

陈列柜内置的电气装置由位于柜子底座的控制设备组成。相关线路图和部件清单跟用户使用说明书在同一个密封塑料袋里。请将这些文件和用户使用说明书一起妥善保管。陈列柜的铭牌上（页5，图12）标明的技术参数在第5页表III里列出。陈列柜运行时产生的噪声低于70分贝。陈列柜不产生有害振动。

我们在此声明陈列柜符合1992年1月25日颁布的N 108法令，因为执行了ECC 89/109标准中和食物接触的物料的规定。

我们在此声明陈列柜适合冷冻冷藏产品的存放，符合1942年4月30日颁布的第283号法令及其随后的修改法令，以及发表在1981年3月26日《官方公告》中的第85号法令（颁布日期：1981年1月29日）。

温度调节器只能由售后服务技术调节时使用。

## 7. 装货

将柜子接通墙面电源并打开陈列柜电源开关。陈列柜将开始启动制冷系统。在往陈列柜里放货前陈列柜需运转两小时才能达到货物存储温度。对陈列柜的预期性能已作了出厂设置。

往陈列柜里放货时请确认：

- 货品的大小和品种类似；
- 货品未超过装货界限并且不会影响到冷空气的正常流动（参看页6，图15）。

## 8. 使用方法

本陈列柜被设计和制造为专门用于存放冰激凌和冷冻食品（L级），此类型的常温陈列柜用来存放预包装的新鲜食品（M级）。陈列柜的功能主要是保持食物的温度，而不是降低食物的温度。所以，当放入食品时，食品处于保鲜温度。不能放入加热过的食品。当搬运冰激凌或者冷冻食品时请佩戴带衬垫的手套。

为了更好的使用陈列柜我们推荐以下操作：

- 如前所述的向陈列柜里放货；
- 如果安装了夜间帘，请在非营业时间使用（图14）：这可以避免不必要的能量损耗并且有利于食品的保存。

## 控制器概述

陈列柜在底座上有个控制面板。这个控制板上有一个分离式温度计/分离式调温器用来显示温度并可以使用特定的钥匙控制温度。

警告：只有专业人士才可以进行温度调节工作。

警告：无论什么原因都不能取下机组和控制板的保护罩。

## 除霜

柜子除霜的数量和间隔已作了出厂设置。

警告：用户绝对不能改变解霜设置。

陈列柜配备了一个用来连接下水系统的U型井（只能由负责安装的售后服务人员实施）。

## 9. 规定和限制

严格禁止将药剂产品、玻璃瓶或瓶装物品放在陈列柜里，这些物品可能会破碎并引起一些安全隐患（图13）。

不能移动需要用工具才能取下的盖子或者面板，不能移动电子控制板的盖子。

不能将陈列柜放在室外（图17）。

不能直接或间接的将水倒在陈列柜上（图16）。不能用湿的手或脚接触陈列柜，赤脚时不能操作陈列柜（图18）。

不能踩踏防撞条。

本说明书中未说明的其他用途都被认为是危险的。厂商对因不规范的、不正确的或者不合理的使用而产生的一切损害不承担任何责任。

## 10. 日常保养

注意：在保养或清洁前，必须给陈列柜断电（图19）。

重要事项：在保养或清洁操作时，确保工作区域光亮充足。如有需要的话，使用别的光源。同时注意热的和活动的部件已经标记上相应标识。推荐使用耐磨手套。

### 清洁陈列柜

(1) 每周清洗陈列柜的外表面，请用温和型肥皂或溶在冷水里的清洗剂，用软布仔细擦拭。不能使用可燃的、洗涤剂、酒精、丙酮或溶剂。不能用水冲洗陈列柜（图16）。只能用玻璃清洁产品清洁玻璃。这里不建议使用水，因为有可能使污垢增多。

(2) 每月按照前面提及的和以下说明的指导清洁陈列柜的内部表面：

- 给陈列柜断电（图19）；



- 取出陈列柜中存放的物品，把这些物品转放到冷库或者其它有足够的达到保温要求能力的冷冻冷藏设备里；
- 等到陈列柜的温度达到室温；
- 使用温和型肥皂或溶在冷水里的清洗剂，用软布仔细擦拭陈列柜内部；
- 在把货物放回前陈列柜需要运行几个小时。

(3) 每3个月陈列柜进行除霜让蒸发器片间形成的冰融化，因为结霜在不同程度影响陈列柜正确的工作。按照第2项清洁内部表面的方法进行，但是允许等待稍长的时间让冰完全融化。

警告：上述没有涉及到的任何保养操作都必须由指定的售后服务或者有资格的人员进行。

## 11. 突发状况

(1) 陈列柜不能启动或者不能继续工作：

- 可能是停电；
- 墙面电源关闭；

如果不是因为上述原因导致电的问题，请立即联系最近的售后服务商，清空陈列柜并将食品转存到冷库或者别的能确保食品正常温度的冷藏冷冻设备里。

(2) 陈列柜制冷不正常：

- 冷凝器可能有污垢所以不能进行热交换。如果是灰尘或者污垢的影响，按照第10节中说明的进行彻底清洁；
- 确认正确的往陈列柜里放货；
- 如果陈列柜超过3个月没有除霜，在正常操作前先除霜和清洁（第10节，第3项）；
- 确认陈列柜没有暴露在热源或者干燥环境里；
- 使用水平仪检查陈列柜是否水平放置。确认环境条件符合第3页的要求。

如果陈列柜继续制冷不足，请与最近的售后服务商联系。

假如有气体泄漏或者起火，在空气流动正常前，需在放置陈列柜的房间里屏住呼吸。关闭柜子前面的电源给柜子断电（参看图19）。不能用水而要用灭火剂来灭火。

(3) 柜子运转噪声

- 确认螺丝螺栓已经拧紧；
- 使用水平仪检查柜子是否水平放置。

如果问题继续存在，请与最近的售后服务商联系。

## 12. 售后报务

需要技术帮助的时候请立即与销售人员联系。如果需要配件，与售后服务商联系：要坚持使用原装配件。

### 13. 分析和处理

为了保护环境，请按照本国垃圾处理法规规定来分类存放陈列柜的部件和材料，从而可以将这些物料正确处理和回收。所有的部件不能被当作城市固体废物，金属部件除外，在欧洲的大部分国家金属部件不被认为是特殊垃圾。组成制冷系统的部件不能重新利用或者单独使用，只能完整的送往专业回收制冷设备的中心。

